

DATA SHEET

TDA1552Q

**2 x 22 W BTL stereo car radio
power amplifier**

Product specification
File under Integrated Circuits, IC01

July 1994

2 x 22 W BTL stereo car radio power amplifier

TDA1552Q

GENERAL DESCRIPTION

The TDA1552Q is an integrated class-B output amplifier in a 13-lead single-in-line (SIL) plastic power package. The circuit contains 2 x 22 W amplifiers in Bridge Tied Load (BTL) configuration. The device is primarily developed for car radio applications.

Features

- Requires very few external components
- High output power
- Low offset voltage at outputs
- Fixed gain
- Good ripple rejection
- Mute/stand-by switch
- Load dump protection
- AC and DC short-circuit-safe to ground and V_P
- Thermally protected
- Reverse polarity safe
- Capability to handle high energy on outputs ($V_P = 0$ V)
- Protected against electrostatic discharge
- No switch-on/switch-off plop
- Low thermal resistance
- Flexible leads.

QUICK REFERENCE DATA

PARAMETER	CONDITIONS	SYMBOL	MIN.	TYP.	MAX.	UNIT
Supply voltage range						
operating		V_P	6.0	14.4	18.0	V
non-operating		V_P	–	–	30	V
load dump protected		V_P	–	–	45	V
Repetitive peak output current		I_{ORM}	–	–	4	A
Total quiescent current		I_{tot}	–	80	160	mA
Stand-by current		I_{sb}	–	0.1	100	μ A
Switch-on current		I_{sw}	–	–	60	μ A
Input impedance		$ Z_I $	50	60	75	k Ω
Junction temperature		T_j	–	–	150	$^{\circ}$ C
Stereo application						
Output power	$R_L = 4 \Omega$; THD = 10%	P_o	20	22	–	W
Supply voltage ripple rejection	$R_S = 0 \Omega$ f = 100 Hz to 10 kHz	RR	48	–	–	dB
DC output offset voltage		$ \Delta V_O $	–	–	150	mV
Channel separation		α	40	–	–	dB
Channel unbalance		$ \Delta G_V $	–	–	1	dB

PACKAGE OUTLINE

13-lead SIL-bent-to-DIL; plastic power (SOT141R); SOT 141-6; 1996 July 23.

2 x 22 W BTL stereo car radio power amplifier

TDA1552Q

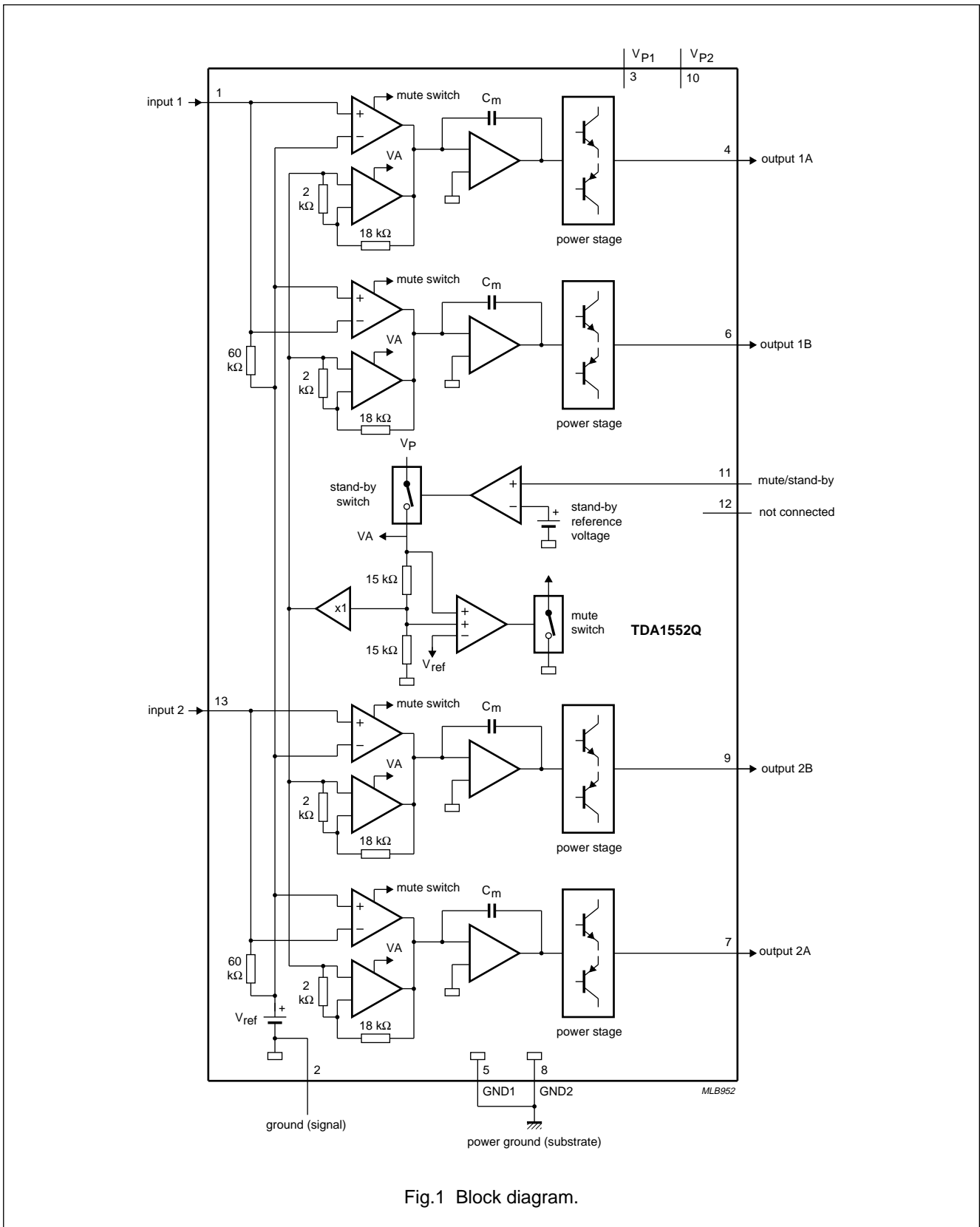

Fig.1 Block diagram.

2 x 22 W BTL stereo car radio power amplifier

TDA1552Q

PINNING

1	IP1	input 1	8	GND2	power ground 2 (substrate)
2	GND	ground (signal)	9	OUT2B	output 2B
3	V _{P1}	positive supply voltage 1	10	V _{P2}	positive supply voltage 2
4	OUT1A	output 1A	11	M/SS	mute/stand-by switch
5	GND1	power ground 1 (substrate)	12	n.c.	not connected
6	OUT1B	output 1B	13	IP2	input 2
7	OUT2A	output 2A			

FUNCTIONAL DESCRIPTION

The TDA1552Q contains two identical amplifiers with differential input stages and can be used for bridge applications. The gain of each amplifier is fixed at 26 dB. A special feature of this device is:

Mute/stand-by switch

- low stand-by current (< 100 μ A)
- low mute/stand-by switching current (low cost supply switch)
- mute facility.

RATINGS

Limiting values in accordance with the Absolute Maximum System (IEC 134)

PARAMETER	CONDITIONS	SYMBOL	MIN.	MAX.	UNIT
Supply voltage					
operating		V _P	–	18	V
non-operating		V _P	–	30	V
load dump protected	during 50 ms; t _r ≥ 2.5 ms	V _P	–	45	V
Non-repetitive peak output current		I _{OSM}	–	6	A
Repetitive peak output current		I _{ORM}	–	4	A
Storage temperature range		T _{stg}	–55	+150	°C
Junction temperature		T _j	–	150	°C
AC and DC short-circuit-safe voltage		V _{PSC}	–	18	V
Energy handling capability at outputs	V _P = 0 V		–	200	mJ
Reverse polarity		V _{PR}	–	6	V
Total power dissipation	see Fig.2	P _{tot}	–	60	W

2 x 22 W BTL stereo car radio power amplifier

TDA1552Q

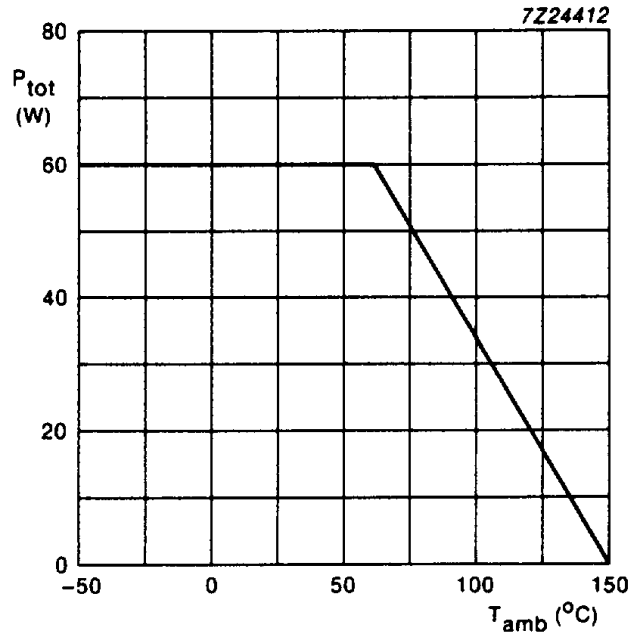

Fig.2 Power derating curve.

2 x 22 W BTL stereo car radio power amplifier

TDA1552Q

DC CHARACTERISTICS

$V_P = 14.4$ V; $T_{amb} = 25$ °C; measurements taken using Fig.3; unless otherwise specified

PARAMETER	CONDITIONS	SYMBOL	MIN.	TYP.	MAX.	UNIT
Supply						
Supply voltage range	note 1	V_P	6.0	14.4	18.0	V
Total quiescent current		I_{tot}	–	80	160	mA
DC output voltage	note 2	V_O	–	6.9	–	V
DC output offset voltage		$ \Delta V_O $	–	–	150	mV
Mute/stand-by switch						
Switch-on voltage level		V_{ON}	8.5	–	–	V
Mute condition						
Output signal in mute position	$V_I = 1$ V (max); $f = 1$ kHz	V_O	–	–	2	mV
DC output offset voltage (between pins 4 to 6 and 7 to 9)		$ \Delta V_O $	–	–	150	mV
Stand-by condition						
DC current in stand-by condition	$V_{II} < 0.5$ V 0.5 V $\leq V_{II} < 2$ V	I_{sb}	–	–	100	μ A
Switch-on current		I_{sw}	–	25	60	μ A
Supply current	short-circuit to GND note 3	I_P	–	5.5	–	mA

2 x 22 W BTL stereo car radio power amplifier

TDA1552Q

AC CHARACTERISTICS

$V_P = 14.4\text{ V}$; $R_L = 4\ \Omega$; $f = 1\text{ kHz}$; $T_{\text{amb}} = 25\text{ }^\circ\text{C}$; measurements taken using Fig.3; unless otherwise specified

PARAMETER	CONDITIONS	SYMBOL	MIN.	TYP.	MAX.	UNIT	
Output power	THD = 0.5%	P_o	15	17	–	W	
	THD = 10%	P_o	20	22	–	W	
Output power at $V_P = 13.2\text{ V}$	THD = 0.5%	P_o	–	12	–	W	
	THD = 10%	P_o	–	17	–	W	
Total harmonic distortion	$P_o = 1\text{ W}$	THD	–	0.1	–	%	
Power bandwidth	THD = 0.5%						
	$P_o = -1\text{ dB}$ w.r.t. 15 W	B_w	-	20 to 15000	–	Hz	
Low frequency roll-off	note 4						
	-1 dB	f_L	–	25	–	Hz	
High frequency roll-off	-1 dB	f_H	20	–	–	kHz	
Closed loop voltage gain		G_v	25	26	27	dB	
Supply voltage ripple rejection	notes 5, 6	RR	42	–	–	dB	
	ON	RR	48	–	–	dB	
	mute	RR	48	–	–	dB	
	stand-by	RR	80	–	–	dB	
Input impedance		$ Z_i $	50	60	75	$k\Omega$	
Noise output voltage (RMS value)							
	ON	$R_S = 0\ \Omega$; note 8	$V_{\text{no(rms)}}$	–	70	120	μV
	ON	$R_S = 10\ k\Omega$; note 8	$V_{\text{no(rms)}}$	–	100	–	μV
	mute	notes 8, 9	$V_{\text{no(rms)}}$	–	60	–	μA
Channel separation		α	40	–	–	dB	
Channel unbalance		$ \Delta G_v $	-	–	1	dB	

Notes to the characteristics

- The circuit is DC adjusted at $V_P = 6\text{ V}$ to 18 V and AC operating at $V_P = 8.5\text{ V}$ to 18 V .
- At $18\text{ V} < V_P < 30\text{ V}$ the DC output voltage $\leq V_P/2$.
- Conditions:
 - $V_{11} = 0\text{ V}$
 - short-circuit to GND
 - switch V_{11} to MUTE or ON condition (rise time $\geq 10\ \mu\text{s}$).
- Frequency response externally fixed.
- Ripple rejection measured at the output with a source impedance of $0\ \Omega$ (maximum ripple amplitude of 2 V).
- Frequency $f = 100\text{ Hz}$.
- Frequency between 1 kHz and 10 kHz .
- Noise voltage measured in a bandwidth of 20 Hz to 20 kHz .
- Noise output voltage independent of R_S ($V_i = 0\text{ V}$).

2 x 22 W BTL stereo car radio power amplifier

TDA1552Q

APPLICATION INFORMATION

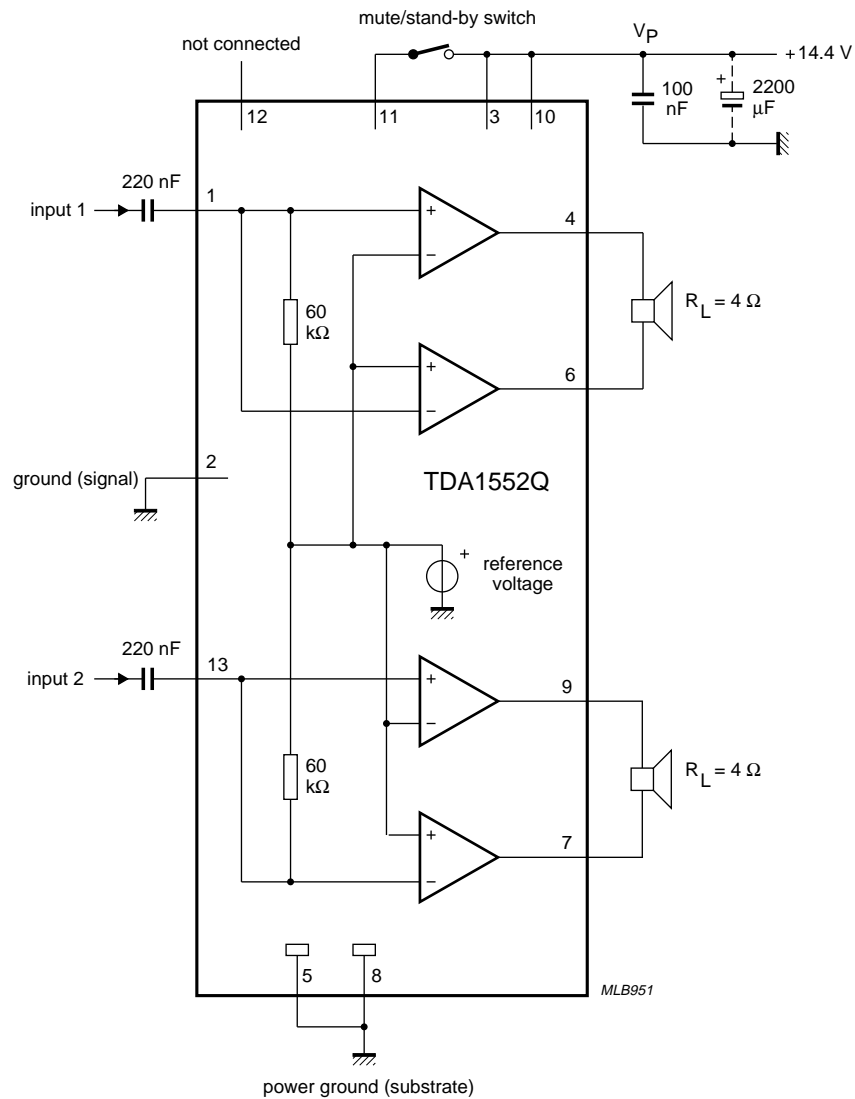

Fig.3 Application circuit diagram.

2 x 22 W BTL stereo car radio power amplifier

TDA1552Q

PACKAGE OUTLINE

DBS13P: plastic DIL-bent-SIL power package; 13 leads (lead length 12 mm)

SOT141-6

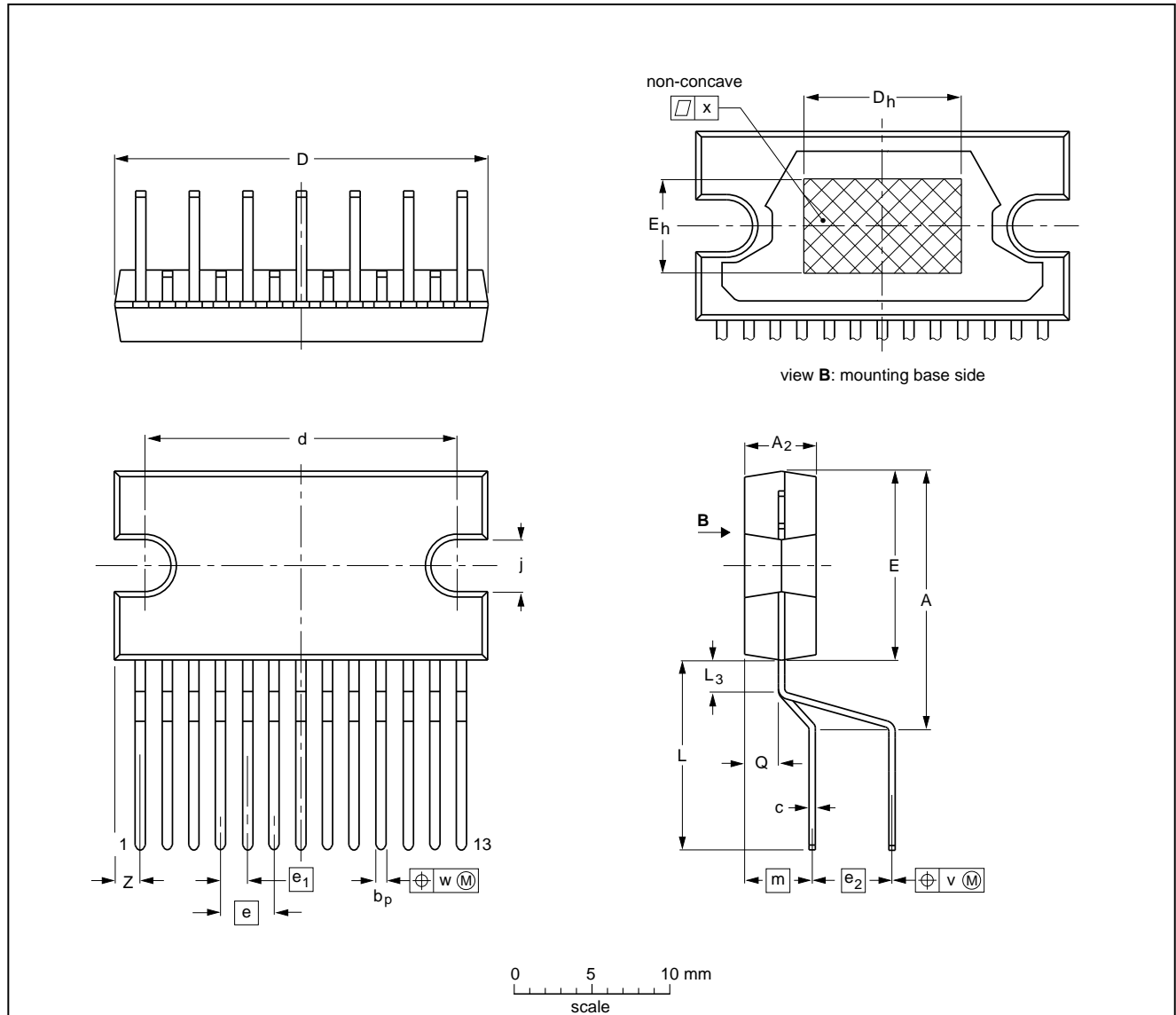

DIMENSIONS (mm are the original dimensions)

UNIT	A	A ₂	b _p	c	D ⁽¹⁾	d	D _h	E ⁽¹⁾	e	e ₁	e ₂	E _h	j	L	L ₃	m	Q	v	w	x	Z ⁽¹⁾
mm	17.0 15.5	4.6 4.2	0.75 0.60	0.48 0.38	24.0 23.6	20.0 19.6	10	12.2 11.8	3.4	1.7	5.08	6	3.4 3.1	12.4 11.0	2.4 1.6	4.3	2.1 1.8	0.8	0.25	0.03	2.00 1.45

Note

1. Plastic or metal protrusions of 0.25 mm maximum per side are not included.

OUTLINE VERSION	REFERENCES				EUROPEAN PROJECTION	ISSUE DATE
	IEC	JEDEC	EIAJ			
SOT141-6						92-11-17 95-03-11

2 x 22 W BTL stereo car radio power amplifier

TDA1552Q

SOLDERING

Introduction

There is no soldering method that is ideal for all IC packages. Wave soldering is often preferred when through-hole and surface mounted components are mixed on one printed-circuit board. However, wave soldering is not always suitable for surface mounted ICs, or for printed-circuits with high population densities. In these situations reflow soldering is often used.

This text gives a very brief insight to a complex technology. A more in-depth account of soldering ICs can be found in our "IC Package Databook" (order code 9398 652 90011).

Soldering by dipping or by wave

The maximum permissible temperature of the solder is 260 °C; solder at this temperature must not be in contact with the joint for more than 5 seconds. The total contact time of successive solder waves must not exceed 5 seconds.

The device may be mounted up to the seating plane, but the temperature of the plastic body must not exceed the specified maximum storage temperature ($T_{stg\ max}$). If the printed-circuit board has been pre-heated, forced cooling may be necessary immediately after soldering to keep the temperature within the permissible limit.

Repairing soldered joints

Apply a low voltage soldering iron (less than 24 V) to the lead(s) of the package, below the seating plane or not more than 2 mm above it. If the temperature of the soldering iron bit is less than 300 °C it may remain in contact for up to 10 seconds. If the bit temperature is between 300 and 400 °C, contact may be up to 5 seconds.

DEFINITIONS

Data sheet status	
Objective specification	This data sheet contains target or goal specifications for product development.
Preliminary specification	This data sheet contains preliminary data; supplementary data may be published later.
Product specification	This data sheet contains final product specifications.
Limiting values	
Limiting values given are in accordance with the Absolute Maximum Rating System (IEC 134). Stress above one or more of the limiting values may cause permanent damage to the device. These are stress ratings only and operation of the device at these or at any other conditions above those given in the Characteristics sections of the specification is not implied. Exposure to limiting values for extended periods may affect device reliability.	
Application information	
Where application information is given, it is advisory and does not form part of the specification.	

LIFE SUPPORT APPLICATIONS

These products are not designed for use in life support appliances, devices, or systems where malfunction of these products can reasonably be expected to result in personal injury. Philips customers using or selling these products for use in such applications do so at their own risk and agree to fully indemnify Philips for any damages resulting from such improper use or sale.